

Generalized Timoshenko Theory of the Variational Asymptotic Beam Sectional Analysis*

Wenbin Yu[†] and Dewey H. Hodges[‡]

Abstract

The generalized Timoshenko theory for composite beams embedded in the computer program VABS has the same structure as Timoshenko's original theory for isotropic beams without the restrictive assumptions of the original theory. An overview of this theory is presented to show its general and rigorous framework. Certain theoretical details missing from previous developments are supplied, such as the proof of a kinematical identity and the expression of the recovery theory in terms of sectional stress resultants. It has been demonstrated that the VABS generalized Timoshenko theory reproduces the elasticity solution for the flexure problem of isotropic prisms. Numerical results are presented in support of the long-term validation effort, focusing especially on calculation of sectional stiffnesses (including shear correction factors) and shear center location, making use of the VABS model for composite beam analysis (including buckling and vibration), and recovering three-dimensional field variables over the section. The accuracy of the VABS generalized Timoshenko theory is demonstrated, and some of its practical advantages over three-dimensional finite element analysis are exhibited.

*Presented at the 44th Structures, Structural Dynamics and Materials Conference, Norfolk, Virginia, April 7 – 10, 2003

[†]Assistant Professor, Department of Mechanical and Aerospace Engineering, Utah State University, Logan, Utah 84322-4130. Formerly, Post Doctoral Fellow, School of Aerospace Engineering, Georgia Institute of Technology, Atlanta, Georgia. Email: wenbin.yu@usu.edu.

[‡]Professor, School of Aerospace Engineering, Georgia Institute of Technology, Atlanta, Georgia, 30332-0150. Email: dewey.hodges@ae.gatech.edu. Fellow, AHS.

Nomenclature

h	beam cross-sectional characteristic dimension
l	wavelength of beam axial deformation
R	characteristic radius of initial curvatures and twists of the beam
A, B, C, D	matrices carrying both sectional geometry and material information in the asymptotic energy model
x_1	beam axial coordinate
x_α	local Cartesian coordinates for the beam section. Greek indices assume values 2 and 3 while Latin indices assume 1, 2, and 3. Repeated indices are summed over their range except where explicitly indicated
$()'$	the partial derivative with respect to x_1
\sim	a notation to convert a 3×1 column matrix into a 3×3 antisymmetric matrix, with $\tilde{\bullet}_{13} = \bullet_2$, $\tilde{\bullet}_{21} = \bullet_3$, and $\tilde{\bullet}_{32} = \bullet_1$.
ε	$[\bar{\gamma}_{11} \ \bar{\kappa}_1 \ \bar{\kappa}_2 \ \bar{\kappa}_3]^T$, column matrix of strain measures as defined in classical beam theory with $\bar{\gamma}_{11}$ as the extensional strain, $\bar{\kappa}_1$ as the torsion, $\bar{\kappa}_\alpha$ as the bending curvatures around x_α
ϵ	$[\gamma_{11} \ \kappa_1 \ \kappa_2 \ \kappa_3]^T$, column matrix of classical strain measures as defined in Timoshenko beam theory with γ_{11} as the extensional strain, κ_1 as the torsion, κ_α as the bending curvatures around x_α
γ_s	$[2\gamma_{12} \ 2\gamma_{13}]^T$, column matrix of transverse strain measures ($2\gamma_{12}$ and $2\gamma_{13}$) defined in Timoshenko beam theory
\mathbf{R}	the position vector of the deformed beam axis
α	$[0 \ 2\gamma_{13} \ -2\gamma_{12}]^T$, column matrix of Rodrigues parameters corresponding to the direction cosine matrix between classical beam system and Timoshenko beam system
k_1, k_2, k_3	initial twist and curvatures of the beam axis
c_α	shear correction factor in the x_α direction
S_α	shear stiffness in the x_α direction

G	shear modulus of an isotropic material
Ω	cross-sectional area
μ	the mass per unit span
i_2, i_3	the mass moments of inertia per unit span about coordinates x_2 and x_3

Introduction

Because of the special geometric feature of beams, in which one dimension is much larger than the other two, beam modeling has been regarded as an elasticity problem for centuries, starting with Galileo's inquiry (Ref. 1). In the more than three hundred years that followed, investigators tried to simplify the analysis by taking advantage of the geometric features to model beams as one-dimensional (1-D) problems. However, to obtain an accurate beam representation for the physically three-dimensional (3-D) structure, one has to find a way to reproduce the 3-D energy stored in the structure as accurately as possible. That is, one must find a way to take into account the eliminated two-dimensional (2-D) cross-sectional coordinates. The famous Euler-Bernoulli hypothesis was introduced to meet this requirement. Therein it is assumed that a normal cross-sectional plane remains plane and normal to the reference line as the beam deforms. The theory resulting from this assumption can account for extension and bending in two directions. To account for torsion, the cross section cannot in general be constrained to remain plane. However, its shape and size in its own plane are assumed to be preserved during torsion, and the cross section can warp out of its plane freely. The simplest beam theories for isotropic beams account for extension, torsion and bending in two directions based on these assumptions and, in spite of the incorporation of Saint-Venant torsion, are sometimes called Euler-Bernoulli beam theories.

Refined theories are required for higher accuracy when the wavelength of the beam deformation is not very large compared to the cross-sectional dimensions. For isotropic beams the next logical step beyond Euler-Bernoulli beam theory is Timoshenko beam theory, in which there are six fundamental global deformations (bending and transverse shear in two directions, extension, and twist). The assumption of Euler-Bernoulli theory is relaxed. Rather,

a cross section of the undeformed beam normal to the reference line will be, in general, oblique to the reference line of the deformed beam because of transverse shearing. To ensure that the reduced 1-D strain energy is equivalent to the original 3-D model over a broader range of slenderness ratios, shear correction factors are often introduced to modify the shear stiffness for isotropic beams. These factors typically reduce the transverse shear stiffness of a cross section relative to what it would have been were there no out-of-plane cross-sectional warping due to transverse shear.

However, for beams made with generally anisotropic materials, the imposition of such *ad hoc* kinematic assumptions can introduce significant errors. To accurately capture the behavior of composite beams, one must abandon these restrictive assumptions and include all possible deformation. In the limit of small h/l , the resulting theory governs fully coupled extension, twist, and bending. Thus, instead of four fundamental stiffnesses there could be as many as 10 (a fully populated 4×4 symmetric matrix). Such a generalized Euler-Bernoulli theory is typically termed “classical beam theory” and can predict well the static and low-frequency dynamic behavior of slender, composite beams (Ref. 2). The stiffness model of classical theory can be refined to take initial twist and curvature into account without changing the types of deformation or the number of stiffness constants (Ref. 3). The 3-D transverse shear effects are only taken into account for the calculation of extension, twist, and bending stiffness constants.

Although for many cases of static and low-frequency dynamic deformation of beams it is shown in Ref. 4 that an asymptotically correct classical model is at least as accurate as refined theories based on *ad hoc* assumptions, classical theory has its limitations. It is not only possible but desirable to generalize Timoshenko theory for composite beams, so that transverse shearing beam variables and short-wavelength phenomena can be included in the model. A significant literature review is beyond the scope of this paper. However, recent research has resulted in significant advances in this field (Refs. 4–7).

One of the developments pointed out in the more recent review papers is the computer

program VABS (Variational Asymptotic Beam Sectional Analysis), a finite element based cross-sectional analysis for composite beam-like structures developed by Hodges and co-workers over the past decade (Refs. 8–15). VABS takes the Variational Asymptotic Method (VAM) as the mathematical foundation to decouple a general 3-D nonlinear anisotropic elasticity problem into a linear, 2-D, cross-sectional analysis and a nonlinear, 1-D, beam analysis (Ref. 16). The cross-sectional analysis calculates the 3-D warping functions asymptotically and finds the constitutive model for the 1-D nonlinear beam analysis. After one obtains the global deformation from the 1-D beam analysis, the original 3-D fields (displacements, stresses, and strains) can be recovered using the obtained 3-D warping functions.

VABS can perform a classical analysis for beams with initial twist and curvature with arbitrary reference cross sections. VABS is also capable of capturing the trapeze and Vlasov effects, which are useful for specific beam applications. VABS is able to calculate the 1-D sectional stiffness matrix with transverse shear refinement for any initially twisted and curved, inhomogeneous, anisotropic beam with arbitrary geometry and material properties. Finally, VABS can recover asymptotically correct 3-D displacement, stress and strain fields within a cross section. To the best of the authors' knowledge, there does not exist any other published treatment of nonlinear composite beam modeling with such generality and versatility. It should be emphasized, however, that the recovery operations within cross sections that are near beam boundaries, concentrated loads, or sudden changes in the cross-sectional geometry along the span are not accurate. Indeed, in these areas one has truly 3-D behavior which cannot be modeled using a beam model.

To emphasize that *ad hoc* assumptions such as those used in the original Timoshenko theory are not invoked in development of the VABS composite beam theory accounting for transverse shear effects it is referred to as a *generalized Timoshenko theory*. For composite beams, instead of six fundamental stiffnesses, there could be as many as 21 terms in a fully populated 6×6 symmetric matrix. The purpose of this paper is to explain, validate, and assess this theory embedded in VABS.

First, an overview of the VABS generalized Timoshenko theory is presented along with a few theoretical details missing from previous treatments of this topic, such as Refs. 14,15. Then, the relation between VABS and elasticity theory is briefly reported as an analytical validation of the theory, building on Ref. 17. Finally, several examples are presented as numerical validations in which VABS results are compared with those from the commercial finite element analysis (FEA) package ANSYS and other approaches in the literature where available and appropriate.

The Generalized Timoshenko Theory of VABS

Construction of strain energy density

The first step of developing the generalized Timoshenko beam theory of VABS is to find a strain energy asymptotically correct up to the second order of h/l and h/R . A complete second-order strain energy is shown to be sufficient for the purpose of constructing a generalized Timoshenko model because it is generally accepted that the transverse shear strain measures are one order less than classical beam strain measures (extension, torsion and bending in two directions). The 3-D strain field in terms of beam strain measures and arbitrary warping functions can be obtained by formulating the beam kinematics exactly in an intrinsic fashion. The 3-D warping functions can be solved by VAM asymptotically and a strain energy asymptotically approximating the 3-D energy up to the second order can be achieved (Ref. 14). The resulting asymptotically correct strain energy is

$$2U^* = \varepsilon^T A \varepsilon + 2\varepsilon^T B \varepsilon' + \varepsilon'^T C \varepsilon' + 2\varepsilon^T D \varepsilon'' \quad (1)$$

Although the strain energy expressed in Eq. (1) is asymptotically correct, it is difficult to use in practical analyses because it contains derivatives of the classical strain measures, which requires boundary conditions that are more complicated than necessary. Timoshenko beam theory, commonly used in engineering practice, is free from such drawbacks. Therefore, the second step is to fit the obtained asymptotically correct strain energy, Eq. (1), into a

generalized Timoshenko model of the form

$$2U = \epsilon^T X \epsilon + 2\epsilon^T F \gamma_s + \gamma_s^T G \gamma_s \quad (2)$$

Generally, it is impossible to achieve this transformation while keeping the resulting model asymptotically correct. Although it is noted that Berdichevsky & Staroselskii (Ref. 18), used changes of variable to achieve a model of the form of Eq. (2), the 1-D transverse shear strain measures are not equivalent to those commonly used. Hence, direct use of the model in Ref. 18 could produce misleading results if one does not take this subtlety into account (Ref. 17). However, one should be able to recover 3-D fields based on that work that are equivalent to those obtained in the VABS generalized Timoshenko theory.

To ensure that the generalized Timoshenko model represents the original asymptotically correct model as accurately as possible, all the known information between these two models should be used. First, the strain measures (ϵ and γ_s) defined in the generalized Timoshenko model can be expressed in terms of the strain measures (ε) defined in the asymptotically correct model. In fact, the strain measures of the asymptotically correct and generalized Timoshenko models are associated with two different triads, \mathbf{T}_i and \mathbf{B}_i , respectively. As shown in Fig. 1, they are related according to

$$\begin{Bmatrix} \mathbf{B}_1 \\ \mathbf{B}_2 \\ \mathbf{B}_3 \end{Bmatrix} = C^{BT} \begin{Bmatrix} \mathbf{T}_1 \\ \mathbf{T}_2 \\ \mathbf{T}_3 \end{Bmatrix} \quad (3)$$

where

$$C^{BT} = \begin{bmatrix} 1 & -2\gamma_{12} & -2\gamma_{13} \\ 2\gamma_{12} & 1 & 0 \\ 2\gamma_{13} & 0 & 1 \end{bmatrix} \quad (4)$$

Based on the definition of 1-D “force-strain” measures (Ref. 19), the identity

$$\mathbf{R}' = (1 + \gamma_{11})\mathbf{B}_1 + 2\gamma_{1\alpha}\mathbf{B}_\alpha = (1 + \bar{\gamma}_{11})\mathbf{T}_1 \quad (5)$$

is obtained. Dot multiplying this equality with \mathbf{B}_1 , making use of Eq. (3), and assuming the strain components are small, then

$$\bar{\gamma}_{11} = \gamma_{11} \quad (6)$$

According to Ref. 19, the “moment-strain” measures can be related by

$$K_B = \frac{(I - \frac{1}{2}\tilde{\alpha})\alpha'}{1 + \frac{1}{4}\alpha^T\alpha} + C^{BT}K_T \quad (7)$$

with I denoting the 3×3 identity matrix and

$$\begin{aligned} K_B &= \kappa + k \\ K_T &= \bar{\kappa} + k \end{aligned} \quad (8)$$

where κ and $\bar{\kappa}$ are the column matrices representing the “moment-strain” measures associated with bases \mathbf{B}_i and \mathbf{T}_i , respectively. The column matrix k contains the initial twist and curvatures measured in basis \mathbf{b}_i . By virtue of the restriction to small strain, the generalized Timoshenko constitutive model being sought is linear. Thus, Eq. (7) can be rewritten as

$$\bar{\kappa} = \kappa - \alpha' + k - C^{BT}k \quad (9)$$

which can be written explicitly as

$$\begin{Bmatrix} \bar{\kappa}_1 \\ \bar{\kappa}_2 \\ \bar{\kappa}_3 \end{Bmatrix} = \begin{Bmatrix} \kappa_1 \\ \kappa_2 \\ \kappa_3 \end{Bmatrix} + \begin{Bmatrix} 0 \\ -2\gamma'_{13} \\ 2\gamma'_{12} \end{Bmatrix} + \begin{Bmatrix} 2\gamma_{1\alpha}k_\alpha \\ -2\gamma_{12}k_1 \\ -2\gamma_{13}k_1 \end{Bmatrix} \quad (10)$$

It should be noted that despite the linearity of the constitutive model, which is a byproduct of the restriction to small strain, the 1-D beam analysis, including both kinematical equations and equations of motion, is geometrically exact (Ref. 19). Combining Eqs. (6) and (10), a kinematical identity is obtained between these two sets of strain measures, namely

$$\varepsilon = \epsilon + Q \gamma'_s + P \gamma_s \quad (11)$$

with

$$Q = \begin{bmatrix} 0 & 0 \\ 0 & 0 \\ 0 & -1 \\ 1 & 0 \end{bmatrix} \quad P = \begin{bmatrix} 0 & 0 \\ k_2 & k_3 \\ -k_1 & 0 \\ 0 & -k_1 \end{bmatrix} \quad (12)$$

Making use of Eq. (11), the asymptotically correct strain energy (Eq. (1)) can be expressed in terms of the generalized Timoshenko beam strain measures as

$$\begin{aligned} 2U^* = & \epsilon^T A \epsilon + 2\epsilon^T A Q \gamma'_s + 2\epsilon^T A P \gamma_s + \\ & 2\epsilon^T B \epsilon' + \epsilon'^T C \epsilon' + 2\epsilon^T D \epsilon'' \end{aligned} \quad (13)$$

To fit Eq. (13) into the generalized Timoshenko form given by Eq. (2), the derivatives of strain measures must be expressed in terms of the strain measures themselves. Fortunately, the 1-D equilibrium equations based on the generalized Timoshenko model provide a convenient way to relate the derivatives of strain measures with the strain measures themselves. Taking advantage of such relations, the unknowns in Eq. (2) can be calculated and a generalized Timoshenko constitutive model can be obtained (Ref. 14).

Recovery relations

There are at least two applications of the generalized Timoshenko model. First, the main application of the constitutive model obtained from VABS is to use it as input for 1-D beam analysis. Although VABS casts the strain energy into a form that has types of

deformation similar to those of the original Timoshenko beam theory, it does not make the limiting kinematical assumptions of that theory. In fact, VABS considers all possible 3-D deformation but still creates a seamless connection to traditional beam theories so that the 1-D beam analysis remains essentially the same. The additional 3-D information, which is eliminated in the construction of the 1-D beam analysis, is included by introducing arbitrary warping functions and is retained to a degree sufficient to give accurate stress, strain, and displacement recovery. Note that any general 1-D beam solver can directly make use of the VABS generalized Timoshenko constitutive model to carry out buckling, dynamic, static and aeroelastic analyses as long as the 1-D beam solver uses 1-D strain measures that are equivalent to the standard ones that are used in the VABS development (Ref. 19). A second application is to use this model to calculate the shear center location for a cross section with arbitrary geometry and material (Refs. 14,15).

There are several criteria for evaluation of composite beam theories and modeling approaches. Although it is necessary for a methodology to provide accurate results for the various types of beam global behavior (i.e., static deflections, natural frequencies, mode shapes, nonlinear transient behavior, buckling loads, etc.), this is not sufficient. Indeed, it is misleading to focus only on the 1-D behavior, per se, because an insufficiently detailed study of published results may lead one to believe that differences among the various published composite beam theories are insignificant. Actually, the adequacy of a composite beam modeling approach should be measured based on how well it predicts 3-D behavior of the original 3-D structure. Therefore, a full set of recovery relations should be provided to complete the modeling. Recovery relations are expressions for the 3-D displacements, strains and stresses in terms of 1-D beam quantities and the local cross-sectional coordinates, x_α .

Such relations are provided in the VABS generalized Timoshenko model. The recovery relations of the 3-D strains and stresses in terms of the 1-D generalized strains and their derivatives are reported briefly in Ref. 15. However, it is difficult to obtain the strain derivatives if the 1-D analysis is solved by a 1-D finite element method using lower-order

shape functions. To be consistent with the procedure used to construct the generalized Timoshenko theory, the final version of recovery theory in VABS for 3-D displacements, strains and stresses is expressed in terms of sectional stress resultants and the applied and inertial loads using the 1-D equations of motion.

For modeling an initially curved and twisted beam, the warping that is asymptotically correct up to the order of h/R and h/l can be expressed as

$$w(x_1, x_2, x_3) = (V_0 + V_{1R})\varepsilon + V_{1S}\varepsilon' \quad (14)$$

where $w(x_1, x_2, x_3)$ is the column matrix of the 3-D warping functions, V_0 , V_{1R} , and V_{1S} are the asymptotically correct warping functions for classical modeling, the correction due to initial curvatures/twist, and the refined warping of the order of h/l , respectively.

The recovered 3-D displacement field of the generalized Timoshenko model can be expressed as

$$U_i(x_1, x_2, x_3) = u_i(x_1) + x_\alpha [C_{\alpha i}(x_1) - \delta_{\alpha i}] + w_i(x_1, x_2, x_3) \quad (15)$$

where U_i are the 3-D displacements, u_i are the 1-D beam displacements, $C_{\alpha i}$ are components of the direction cosine matrix representing the rotation of beam triads during deformation, and $\delta_{\alpha i}$ is the Kronecker symbol. Strictly speaking, although the warping field has been calculated only to first order, the strain energy density is asymptotically correct through the second order in the small parameters. With the first-order warping, the 3-D fields can only be recovered through the first order. Recovering the 3-D fields up to the second order requires calculation of the second-order warping field, which means additional complexity and computation. Here the 3-D results will be recovered based on the first-order warping and all the other information available. Numerical examples show that such recovery relations yield accurate results without introducing additional computational cost.

The 3-D strain field can be recovered as follows:

$$\begin{aligned}
\Gamma &= [(\Gamma_h + \Gamma_R)(V_0 + V_{1R}) + \Gamma_\epsilon] \epsilon \\
&+ [(\Gamma_h + \Gamma_R)V_{1S} + \Gamma_l(V_0 + V_{1R})] \epsilon' \\
&+ \Gamma_l V_{1S} \epsilon''
\end{aligned} \tag{16}$$

where the 3-D field is

$$\Gamma = [\Gamma_{11} \quad 2\Gamma_{12} \quad 2\Gamma_{13} \quad \Gamma_{22} \quad 2\Gamma_{23} \quad \Gamma_{33}]^T \tag{17}$$

All the operators in Eq. (16) can be found in Ref. 14. It is more useful to write the recovery relations in terms of stress resultants because those quantities and their derivatives can be obtained through the 1-D equilibrium equations. Denoting S as the 6×6 stiffness matrix for the generalized Timoshenko beam model, the generalized strain measures can be obtained in terms of sectional stress resultants as

$$\epsilon_t = S^{-1} F \tag{18}$$

where $\epsilon_t = [\gamma_{11} \quad 2\gamma_{12} \quad 2\gamma_{13} \quad \kappa_1 \quad \kappa_2 \quad \kappa_3]^T$ are the generalized 1-D strain measures obtained from a generalized Timoshenko model, and $F = [F_1 \quad F_2 \quad F_3 \quad M_1 \quad M_2 \quad M_3]^T$ the cross-sectional stress and moment resultants. To find the derivatives of stress resultants, the 1-D nonlinear equilibrium equations can be arranged as

$$F' = \begin{bmatrix} \widetilde{K}_B & \widetilde{0} \\ \widetilde{e}_1 + \widetilde{\gamma} & \widetilde{K}_B \end{bmatrix} F - f \equiv -\mathcal{R}F - f \tag{19}$$

with

$$\gamma = [\gamma_{11} \ 2\gamma_{12} \ 2\gamma_{13}]^T \quad (20)$$

$$e_1 = [1 \ 0 \ 0]^T \quad (21)$$

$$f = [f_1 \ f_2 \ f_3 \ m_1 \ m_2 \ m_3]^T \quad (22)$$

where f are the known distributed 1-D generalized applied and inertial loads. Note that the generalized strains in Eq. (19) can be obtained from Eq. (18). It is clear that Eq. (19) can be differentiated on both sides to get higher derivatives as

$$\begin{aligned} F'' &= (\mathcal{R}^2 - F')F + \mathcal{R}f - f' \\ F''' &= (-\mathcal{R}^3 + \mathcal{R}\mathcal{R}' + 2\mathcal{R}'\mathcal{R} - \mathcal{R}'')F + (-\mathcal{R}^2 + 2\mathcal{R}')f + \mathcal{R}f' - f'' \end{aligned} \quad (23)$$

Having F' , F'' and F''' , one can obtain ϵ'_t , ϵ''_t and ϵ'''_t from Eq. (18). Substituting these values into Eq. (16) and using Eq. (11), the 3-D strain field can be expressed in terms of the known quantities F , f , f' and f'' from the 1-D beam analysis. Finally, the 3-D stress field can be obtained using the 3-D constitutive law. The results obtained from use of these recovery relations are identically the same as from those written in terms of 1-D strains and their derivatives; see Ref. 15.

Validation of the VABS Generalized Timoshenko Theory

The aforementioned generalized Timoshenko theory for initially curved and/or twisted composite beams has been implemented in the computer program VABS. VABS is a versatile computer program for design and analysis of composite beam-like structures. Here, more validation is provided to demonstrate further the accuracy and versatility of this theory.

Validation of VABS can be undertaken in two different ways. One is analytical and the other numerical. Several examples are given in this section to support the continuing validation of the generalized Timoshenko theory of VABS. The examples include isotropic

and anisotropic cases. The comparison is made against 3-D elasticity theory, 3-D FEA and other published results whenever possible and appropriate.

Analytical validation

Analytical validation of VABS is accomplished by establishing the connection between VABS and 3-D elasticity theory. The first such example appeared in Ref. 15 in which the variational asymptotic cross-sectional analysis of an elliptic isotropic prism with transverse shear refinement is solved by using Ritz method. Later, a one-to-one correspondence between the 3-D elasticity theory and the VABS generalized Timoshenko theory was found (Ref. 17). There, the general formulation from VABS is specialized to treat isotropic, prismatic beams. The governing differential equations and associated boundary conditions of the VABS classical model and generalized Timoshenko model are exactly the same as those of the Saint-Venant problem and flexure problem in 3-D elasticity theory, respectively. This discovery demonstrates that VABS yields exact results for shear correction factors and shear center location for isotropic prismatic beams. Therefore, any existing model that does not produce the same results as VABS does for these kinds of beams should be considered inferior. The fact that VABS reproduces the results of elasticity theory clearly confirms the fact that VABS avoids the difficulties of dealing with 3-D elasticity while at the same time obtains results that agree very well with exact solutions.

Although it may not be possible to analytically validate the general theory of VABS for anisotropic beams in the same way, it is a natural deduction based on the derivation of Ref. 17 that the results for generally anisotropic beams should be the same as those calculated by methods based on 3-D anisotropic elasticity theory, such as 3-D FEA. Indeed, VABS may be considered as a means for going beyond those limits when considering the cross-sectional analysis of beam-like structures just as 3-D FEA allows one to go beyond the limitations of 3-D elasticity. When coupled with a suitable 1-D beam solver, 3-D stresses on the interior of a beam are obtained for a computational cost that is two to three orders of magnitude less than that of 3-D FEA.

Numerical validation examples

Another means of validation is to compare results from VABS with those published and with 3-D FEA. Most of the numerical examples presented in previous publications on VABS are validations of this kind; see Refs. 9, 10, 12–15. In Ref. 15 some VABS results are assessed against the 3-D FEA package ABAQUS.

In this section, several numerical examples will be investigated to demonstrate the accuracy and advantages of the VABS generalized Timoshenko theory. The problems related with generalized Timoshenko modeling of composite beams can be classified into the following three groups:

1. Obtaining the matrix of cross-sectional stiffness constants for general beams, particularly the transverse shear stiffnesses or shear correction factors for isotropic sections.
2. Locating the shear center, especially for structures that are anisotropic and not thin-walled.
3. Recovering 3-D results for the purpose of detailed analysis.

Stiffness model and shear correction factors. One of the main outcomes of a generalized Timoshenko model is a 6×6 stiffness model including the transverse shear stiffnesses for a cross section. Particularly, for isotropic sections, shear correction factors are often used to obtain the equivalent shear stiffness to be used for a Timoshenko beam analysis. These factors are defined as

$$c_\alpha = \frac{S_\alpha}{G\Omega} \quad (24)$$

Taking for example a rectangular section with a length of $2a$ in the x_2 direction and $2b$ in the x_3 direction, the factor $5/6$ is normally used in engineering practice. However, this number is only correct for the x_2 direction when $b \ll a$ and/or the Poisson's ratio $\nu = 0$.

The exact factor can be obtained by the VABS generalized Timoshenko theory as

$$c_2^{-1} = \frac{6}{5} + \left(\frac{\nu}{1 + \nu} \right)^2 \left[\frac{1}{5\rho^4} - \frac{18}{\rho^5 \pi^5} \sum_{m=1}^{\infty} \frac{\tanh(m\pi\rho)}{m^5} \right] \quad (25)$$

with $\rho = a/b$. As mentioned in Ref. 17, Eq. (25) is exactly the same as that obtained from the flexure problem of elasticity theory. The same result was also obtained independently in Refs. 20,21. There are other values proposed in the literature (Refs. 18,22,23), but these are only approximations to the exact value and not as accurate as what VABS calculates.

Eq. (25) is obtained by mathematically solving the governing differential equations of the VABS generalized Timoshenko theory. Letting $2a = 1$ in., $2b = 2$ in., $G = 10^9$ psi and $\nu = 0.3$, then the exact value of c_2 is 0.784442. To study that the computer program VABS is a faithful implementation of the theory behind it, seven different meshes: 1×2 , 2×4 , 3×6 , 4×8 , 5×10 , 6×12 and 10×20 , where the first number is the number of elements along x_2 and the second is the number of elements along x_3 , are created for this purpose. The section is meshed by ANSYS *shell93* elements and this mesh is imported to VABS using special-purpose macros created for interfacing VABS and ANSYS. The results for the relative error of c_2 with respect to the exact result are plotted in Fig. 2 versus the number of elements along x_2 on a log-log scale. It is apparent that the numerical results from VABS converge monotonically to the exact result as one refines the mesh. Even if the mesh is only comprised of 8 elements, the difference between the VABS numerical result and the exact solution is less than 1%.

To demonstrate that VABS can calculate the shear correction factors correctly for arbitrary sections, an irregular section as sketched and meshed in Fig. 3 is studied. VABS results are compared with those of Ref. 24 and ANSYS beam capability (*beam 188/189*) in Table 1. VABS results agree with those from Ref. 24 to within 0.2%, while ANSYS results are off by as much as 1.3%. Note that the results from ANSYS are independent of Poisson's ratio and so can be only considered as approximations to the exact solution when $\nu = 0$. Although

it is said in the ANSYS manual that the cross-sectional capability is valid for composite sections, the word “composite” just means that one can build up several isotropic sections into an arbitrary section. It is *not* applicable to sections made with anisotropic materials. It should be noted that the work of Ref. 24 is devoted to calculate the shear correction factors only for arbitrary isotropic sections, which is much less versatile than VABS because this capability is just a small subset of the VABS functionalities.

Usually, when the six global deformations are uncoupled, it is sufficient to obtain the shear correction factors instead of calculating the 6×6 stiffness matrix. However, more often than not, the global deformations are coupled, and the full stiffness matrix is needed. Especially for composite beams, the stiffness matrix is generally coupled (Refs. 14,15). Here a more complex composite beam with a cross section described in Fig. 4 is modeled by VABS. This cross section is comprised of two straight strips and two half circles, each of which is made with two laminated layers. The material properties are listed in Table 2, and the dimensions are given in Fig. 4. The cross-sectional properties are listed in Table 3, from which extension-twist and shear-bending couplings are evident. The results labelled as “SVBT” are produced by a computer program based on Ref. 25, a generalized application of the Saint-Venant approach. Therein, the behavior of all quantities versus the axial coordinate is represented by polynomials of zeroth and first degree, while the cross-sectional variations are handled by means of finite element approximation. Although SVBT is not based on asymptotic methods, the results from it and from VABS agree very well for most cases compared to date. The generalized Saint-Venant methodology, however, is limited to linear analysis and lacks rigorous connections to treatments of end effects, such as are modeled by Vlasov theory.

Based on the above, in combination with previously published demonstrations, it can be concluded that the generalized Timoshenko stiffness model of VABS can be used confidently to carry out structural analysis for a wide variety of beam cross-sectional geometries and materials.

Locating the shear center. Another important outcome of generalized Timoshenko modeling is the shear center location. For thin-walled sections this is straightforward, but for arbitrary sections there is not much published information. Although it is not a common practice to carry out generalized Timoshenko modeling to find the shear center, it is indeed very simple to accurately locate the shear center after an accurate 6×6 stiffness model such as that from VABS is obtained.

The first example is an isotropic open channel-like section with unequal edges and equal thickness (see Fig. 5) studied in Ref. 26. VABS results are compared against those of Ref. 26 and ANSYS. As shown in Table 4, the three sets of results agree within 1.7% for c_2 and to three significant figures for c_3 .

Another example studied in Ref. 26 is a closed section with three cells (see Fig. 6 for geometry and mesh). Again the results from VABS (Ref. 26) and ANSYS are compared in Table 5 and agreement to within 0.5% is found.

While most research concerning the shear center is focused on isotropic, thin-walled sections, VABS can also locate the shear center for generally anisotropic cross sections, whether or not they are thin-walled. On this subject not much work can be found in the literature.

Beam analysis with the VABS generalized Timoshenko model. Composite beam modeling does not stop at the stage of obtaining the cross-sectional properties such as beam stiffness matrix (including shear correction factors), and shear center location, etc. The ultimate goal of beam modeling is to use the obtained sectional properties to carry out the 1-D beam analysis to predict the global behavior, such as deflections, buckling load, natural frequencies and so on. Here, we assume the cross section in Fig. 4 is cut from a cantilever beam with

length $L = 20$ in. The sectional mass properties obtained by VABS are

$$\begin{aligned}
 \mu &= 1.92162 \times 10^{-4} \text{ lb.sec}^2/\text{in.}^2 \\
 i_2 &= 2.55781 \times 10^{-5} \text{ lb.sec}^2 \\
 i_3 &= 1.58341 \times 10^{-4} \text{ lb.sec}^2
 \end{aligned} \tag{26}$$

The VABS stiffness model (Table 3) and sectional inertial properties in Eq. (26) are used along with a 1-D nonlinear beam solver; here DYMORE (Ref. 27) is used to carry out a 1-D dynamic analysis to obtain the natural frequencies and a 1-D buckling analysis to obtain the critical Euler buckling load (compression). The natural frequencies for the first three bending modes are listed in Table 6, where $b_{i\alpha}$ denotes the i th bending mode in the direction of x_α . Model 1 is the generalized Timoshenko model given in Table 3, and Model 2 is the corresponding classical model. It should be noted that the 4×4 matrix of classical stiffness constants can be found by inverting the 6×6 cross-sectional stiffness matrix from the generalized Timoshenko model, removing the two columns associated with transverse shear, and then inverting the resulting 4×4 matrix. Table 6 shows that there is a significant difference of the second and higher bending modes between the natural frequencies obtained from the generalized Timoshenko and classical models. It is clear that the classical model lacks predictive capability for the higher bending modes and that to obtain accurate second and higher flapping and lagging frequencies for a composite rotor blade, one should use the generalized Timoshenko model. Notice that there is no difference between the two models for torsional frequencies.

A static stability problem has also been studied for this composite beam. The tip deflection is excited by a very small tip shear force. As apparent from the plots, when the compression load approaches the critical load, there is an abrupt change of the tip deflection. There is a small difference (3.5%) between the results obtained from classical and generalized Timoshenko models (see Fig. 7).

Recovering 3-D results. Another capability of VABS is that it can recover the asymptotically correct distributions of the 3-D fields (displacements, strains, and stresses) over the cross section after obtaining the 1-D global behavior, which is very important for analyzing the failure of some critical areas. For demonstration purposes, consider a composite beam of length 5 inches with a rectangular cross section, dimensions of which are $b=0.25$ inches, and $h=1$ inch (Fig. 8). The material properties are given in Table 7, and the layup is a repeating quasi-isotropic pattern with 80 layers.

A unit shear force was applied in the x_3 direction at one end, and the other end was constrained to have zero displacement at every node. This means that the VABS model requires an input of $F_3=1$ lb, and $M_2=2.5$ lb-in for the purpose of recovering the stress components on the cross section at the mid-span of the beam ($x_1 = 2.5$ in); specifically, the stress along the line $x_2 = 0$ for various x_3 locations. For the ANSYS run, the total number of elements was 25,600, and about one hour of computer time was required. For the VABS run, the number of elements was 640, and the computer time was less than two seconds. As can be seen for stress components τ_{13} and τ_{12} in Figs. 9 and 10, respectively, the results from VABS are almost on top of those of ANSYS.

The 3-D stress distributions clearly identify which areas within a cross section are experiencing extreme stresses. This capability of VABS enables the designer to make certain adjustments to avoid possible damage in the structure before it is actually built and tested. This means that the cost of a composite beam structure may be reduced. It should be emphasized, however, that the VABS analysis can only provide accurate stresses away from beam boundaries, concentrated loads, and sudden changes in the cross-sectional geometry along the span. In these areas one has truly 3-D behavior, and the structure does not behave as a beam.

Conclusions

An overview of the VABS generalized Timoshenko theory has been presented so that the generality and rigor of the framework can be emphasized and exhibited. Certain theoretical

derivations that were missing from earlier publications have been presented. These include a proof of the kinematical identity and a presentation of the recovery theory in terms of sectional stress resultants. A complete formulation of the theory is now available. Examples have been presented to demonstrate that the generalized Timoshenko theory in VABS can reproduce the results of elasticity theory, accurately find the shear correction factors, and locate the shear center for beams made from anisotropic materials. It is also shown that the generalized Timoshenko model obtained from VABS can be used to carry out 1-D beam analyses such as buckling, vibration, etc. Significant differences are found between the results from the classical beam model and the generalized Timoshenko model. VABS can also be used to recover the 3-D distribution over the cross section with much less modeling and computational time relative to 3-D FEA.

The VABS generalized Timoshenko theory provides an accurate prediction of the behavior of the original 3-D beam structure because it asymptotically approximates the 3-D elasticity theory for the interior behavior of beams. It can predict the required results with much less labor time and computational time. Designers should be able to use this tool at both preliminary and detailed design stages to carry out needed tradeoffs more effectively, so that better and more cost-effective composite beam-like structures can be produced.

Acknowledgements

This work was supported in part by the National Rotorcraft Technology Center through the Georgia Tech Center of Excellence in Rotorcraft Technology and by the Rotorcraft Industry Technology Association. The authors gratefully acknowledge the help of Eduardo D. Fuchs running ANSYS.

References

¹Love, A. E. H., *A Treatise on the Mathematical Theory of Elasticity*, Dover Publications, New York, New York, 4th ed., pp. 1–3.

²Hodges, D. H., Atilgan, A. R., Cesnik, C. E. S., and Fulton, M. V., “On a Simplified Strain Energy Function for Geometrically Nonlinear Behaviour of Anisotropic Beams,” *Composites Engineering*, Vol. 2, (5–7), 1992, pp. 513–526.

³Cesnik, C. E. S., Hodges, D. H., and Sutyrin, V. G., “Cross-Sectional Analysis of Composite Beams Including Large Initial Twist and Curvature Effects,” *AIAA Journal*, Vol. 34, (9), Sept. 1996, pp. 1913–1920.

⁴Volovoi, V. V., Hodges, D. H., Cesnik, C. E. S., and Popescu, B., “Assessment of Beam Modeling Methods for Rotor Blade Applications,” *Mathematical and Computer Modelling*, Vol. 33, (10–11), 2001, pp. 1099–1112.

⁵Hodges, D. H., “A Review of Composite Rotor Blade Modeling,” *AIAA Journal*, Vol. 28, (3), March 1990, pp. 561–565.

⁶Cesnik, C. E. S., *Cross-Sectional Analysis of Initially Twisted and Curved Composite Beams*, Ph.D. thesis, Aerospace Engineering, Georgia Institute of Technology, May 1994.

⁷Jung, S. N., Nagaraj, V. T., and Chopra, I., “Assessment of Composite Rotor Blade Modeling Techniques,” *Journal of the American Helicopter Society*, Vol. 44, (3), July 1999, pp. 188–205.

⁸Cesnik, C. E. S. and Hodges, D. H., “Stiffness Constants for Initially Twisted and Curved Composite Beams,” *Applied Mechanics Reviews*, Vol. 46, (11, Part 2), 1993, pp. S211–S220.

⁹Cesnik, C. E. S. and Hodges, D. H., “Variational-Asymptotical Analysis of Initially Twisted and Curved Composite Beams,” *International Journal for Engineering Analysis and Design*, Vol. 1, (2), Apr. 1994, pp. 177–187.

¹⁰Cesnik, C. E. S. and Hodges, D. H., “Stiffness Constants for Composite Beams Including Large Initial Twist and Curvature Effects,” *Applied Mechanics Reviews*, Vol. 48, (11, Part 2), 1995, pp. S61–S67.

¹¹Cesnik, C. E. S. and Hodges, D. H., “VABS: A New Concept for Composite Rotor

Blade Cross-Sectional Modeling,” *Journal of the American Helicopter Society*, Vol. 42, (1), Jan. 1997, pp. 27–38.

¹²Popescu, B. and Hodges, D. H., “On Asymptotically Correct Timoshenko-Like Anisotropic Beam Theory,” *International Journal of Solids and Structures*, Vol. 37, (3), 1999, pp. 535–558.

¹³Popescu, B., Hodges, D. H., and Cesnik, C. E. S., “Obliqueness Effects in Asymptotic Cross-Sectional Analysis of Composite Beams,” *Computers and Structures*, Vol. 76, (4), 2000, pp. 533–543.

¹⁴Yu, W., Hodges, D. H., Volovoi, V. V., and Cesnik, C. E. S., “On Timoshenko-Like Modeling of Initially Curved and Twisted Composite Beams,” *International Journal of Solids and Structures*, Vol. 39, (19), 2002, pp. 5101–5121.

¹⁵Yu, W., Volovoi, V. V., Hodges, D. H., and Hong, X., “Validation of the Variational Asymptotic Beam Sectional Analysis,” *AIAA Journal*, Vol. 40, (10), Oct. 2002, pp. 2105–2113.

¹⁶Berdichevsky, V. L., “Variational-Asymptotic Method of Constructing a Theory of Shells,” *Journal of Applied Mathematics and Mechanics*, Vol. 43, (4), 1979, pp. 664–687.

¹⁷Yu, W. and Hodges, D. H., “Elasticity Solutions versus Asymptotic Sectional Analysis of Homogeneous, Isotropic, Prismatic Beams,” *Journal of Applied Mechanics*, Vol. 71, (1), 2004, pp. 15–23.

¹⁸Berdichevsky, V. L. and Starosel’skii, L. A., “On the Theory of Curvilinear Timoshenko-Type Rods,” *Journal of Applied Mathematics and Mechanics*, Vol. 47, (6), 1983, pp. 809–817.

¹⁹Hodges, D. H., “A Mixed Variational Formulation Based on Exact Intrinsic Equations for Dynamics of Moving Beams,” *International Journal of Solids and Structures*, Vol. 26, (11), 1990, pp. 1253–1273.

²⁰Renton, J. D., “Generalized Beam Theory Applied to Shear Stiffness,” *International Journal of Solids and Structures*, Vol. 27, (15), 1991, pp. 1955–1967.

²¹Pai, P. F. and Schulz, M. J., “Shear Correction Factors and an Energy-Consistent Beam Theory,” *International Journal of Solids and Structures*, Vol. 36, (14), 1999, pp. 1523–1540.

²²Stephen, N. G., “Considerations on Second Order Beam Theories,” *International Journal of Solids and Structures*, Vol. 17, (3), 1981, pp. 325–333.

²³Cowper, G. R., “The Shear Coefficient in Timoshenko’s Beam Theory,” *Journal of Applied Mechanics*, Vol. 33, (2), June 1966, pp. 335–340.

²⁴Gruttmann, F. and Wagner, W., “Shear Correction Factors in Timoshenko’s Beam Theory for Arbitrary Shaped Cross-sections,” *Computational Mechanics*, Vol. 27, (3), 2001, pp. 199–207.

²⁵Giavotto, V., Borri, M., Mantegazza, P., Ghiringhelli, G., Carmaschi, V., Maffioli, G. C., and Mussi, F., “Anisotropic Beam Theory and Applications,” *Computers and Structures*, Vol. 16, (1–4), 1983, pp. 403–413.

²⁶Paz, M., Strehl, C. P., and Schrader, P., “Computer Determination of the Shear Center of Open and Closed Sections,” *Computers and Structures*, Vol. 6, (2), 1976, pp. 117–125.

²⁷Bauchau, O., “Computational Schemes for Flexible, Nonlinear Multi-Body Systems,” *Multibody System Dynamics*, Vol. 2, (2), 1998, pp. 169–225.

List of Table Captions

- Table 1:** Shear correction factors for an arbitrary section
- Table 2:** Properties of the anisotropic pipe section
- Table 3:** The sectional stiffness matrix of the anisotropic pipe
- Table 4:** Shear center for the channel section
- Table 5:** Shear center for the 3-cell closed section
- Table 6:** Natural frequencies (rad./sec.) from different models
- Table 7:** Material properties of anisotropic beam with rectangular cross section

ν	Resources	0	0.25	0.5
c_2	VABS	0.7404	0.7367	0.7306
	Ref. 24	0.7395	0.7355	0.7294
	ANSYS	0.7402	0.7402	0.7402
c_3	VABS	0.6780	0.6764	0.6736
	Ref. 24	0.6767	0.6753	0.6727
	ANSYS	0.6778	0.6778	0.6778

TABLE 1:

right wall:	$[45^\circ / -45^\circ]$
left wall:	$[45^\circ / -45^\circ]$
upper wall:	$[90^\circ / 0^\circ]$
lower wall:	$[90^\circ / 0^\circ]$
Material properties:	$E_l = 20.59 \times 10^6$ psi
$E_t = 1.42 \times 10^6$ psi	$G_{lt} = G_{tn} = 8.7 \times 10^5$ psi
$\nu_{lt} = \nu_{tn} = 0.42$	$\rho = 1.47516 \times 10^{-4}$ lb.sec ² /in. ⁴

Stiffness	VABS	SVBT	Rel. error (%)
S_{11} (lb)	1.03890×10^7	1.03892×10^7	0.0019%
S_{22} (lb)	7.84299×10^5	7.85310×10^5	0.13%
S_{33} (lb)	3.29002×10^5	3.29279×10^5	0.084%
S_{14} (lb-in.)	9.82878×10^4	9.84575×10^4	0.17%
S_{25} (lb-in.)	-8.18782×10^3	-8.21805×10^3	0.37%
S_{36} (lb-in.)	-5.18541×10^4	-5.20981×10^4	0.45%
S_{44} (lb-in ²)	6.86973×10^5	6.87275×10^5	0.044%
S_{55} (lb-in ²)	1.88236×10^6	1.88238×10^6	0.0011%
S_{66} (lb-in ²)	5.38972×10^6	5.38987×10^6	0.0028%

TABLE 3:

Resources	c_2 (in.)	c_3 (in.)
VABS	-0.176	0.186
Ref. 26	-0.179	0.186
ANSYS	-0.177	0.186

Resources	c_2 (in.)	c_3 (in.)
VABS	4.356	1.000
Ref. 26	4.337	1.000
ANSYS	4.356	1.001

Modes	Model 1	Model 2	Difference
b_{13}	8.417×10^2	8.693×10^2	3.3%
b_{12}	1.410×10^3	1.465×10^3	3.9%
b_{23}	4.488×10^3	5.423×10^3	20.8%
b_{22}	7.244×10^3	8.932×10^3	23.2%
b_{33}	1.054×10^4	1.507×10^4	43.0%
b_{32}	1.665×10^4	2.399×10^4	44.1%

TABLE 6:

	Layup: $[(-45/+45/0/90)_{10}]_s$
Material properties:	$E_l = 20.59 \times 10^6$ psi
$E_t = 1.42 \times 10^6$ psi	$G_{lt} = G_{tn} = 8.7 \times 10^5$ psi
$\nu_{lt} = \nu_{tn} = 0.42$	$\rho = 1.47516 \times 10^{-4}$ lb.sec ² /in. ⁴

List of Figure Captions

- Figure 1: Coordinate systems used for transverse shear formulation
- Figure 2: Relative error for shear correction factor c_2 showing convergence with mesh refinement
- Figure 3: Geometry and mesh of an arbitrary cross section
- Figure 4: Sketch of the section of an anisotropic pipe
- Figure 5: Sketch of an open section
- Figure 6: Cross section having three closed cells
- Figure 7: Transverse deflection at the tip of of the anisotropic pipe. Solid line: Timoshenko model; dashed line: Classical model.
- Figure 8: Schematic of rectangular beam cross section
- Figure 9: Stress component τ_{13} at mid-span and $x_2 = 0$
- Figure 10: Stress component τ_{12} at mid-span and $x_2 = 0$

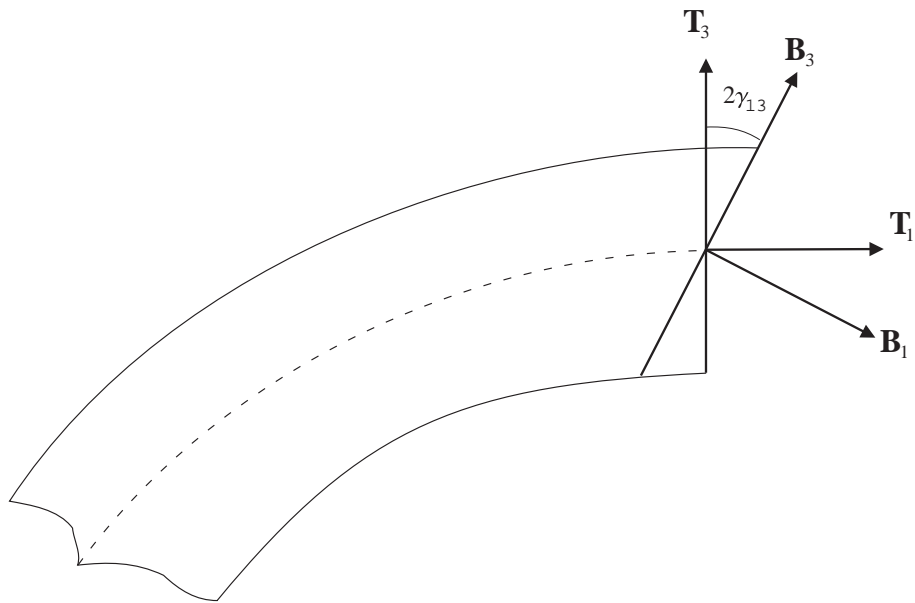

FIGURE 1:

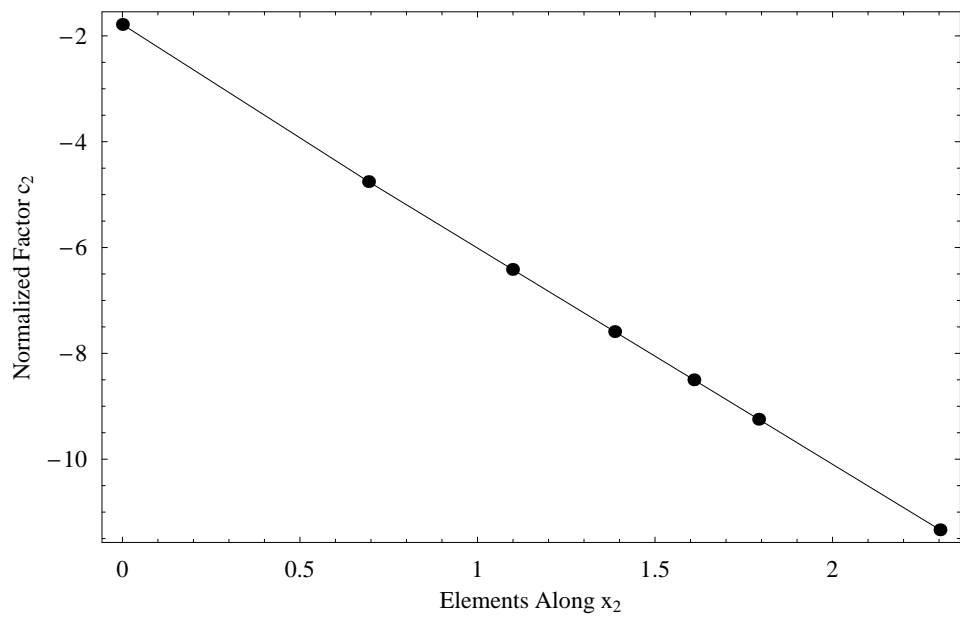

FIGURE 2:

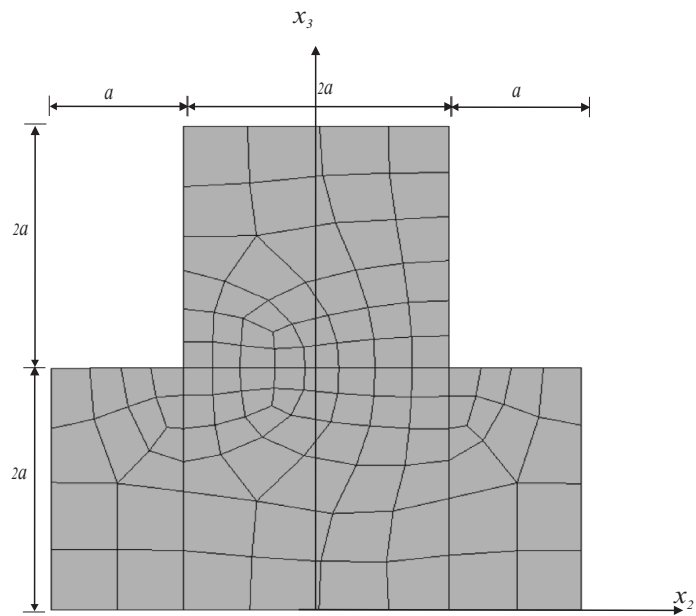

FIGURE 3:

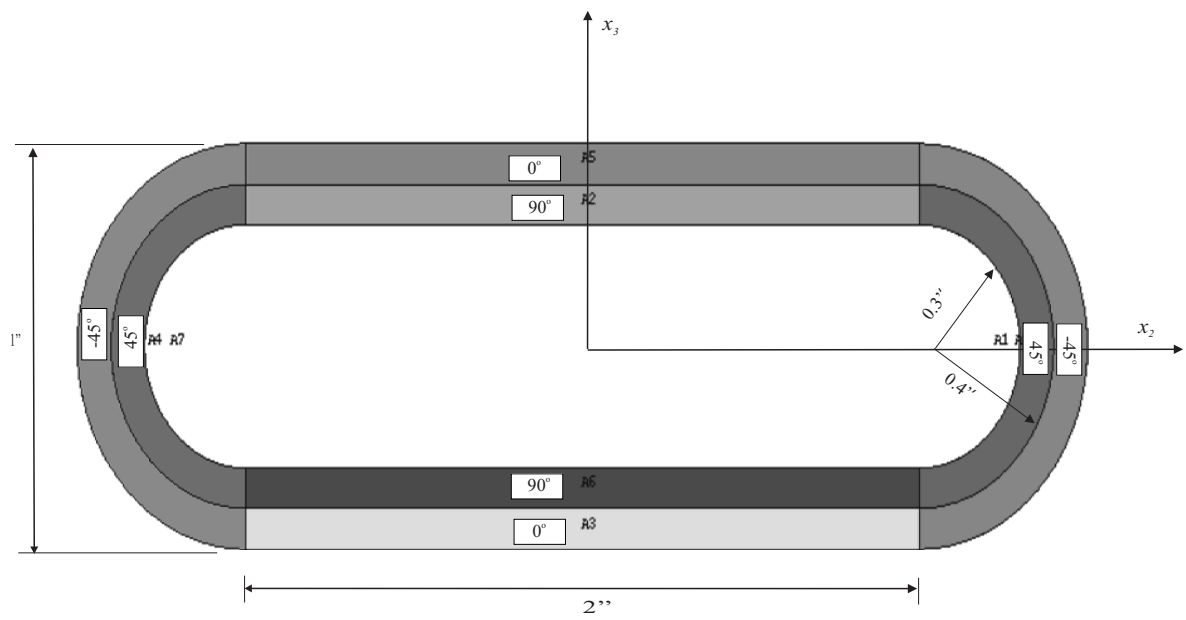

FIGURE 4:

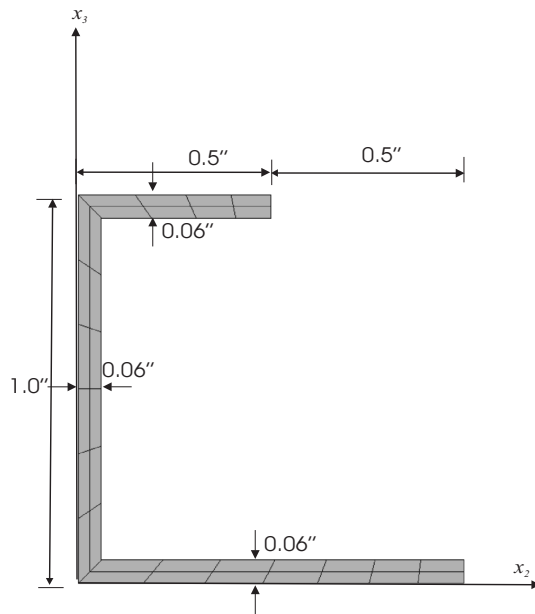

FIGURE 5:

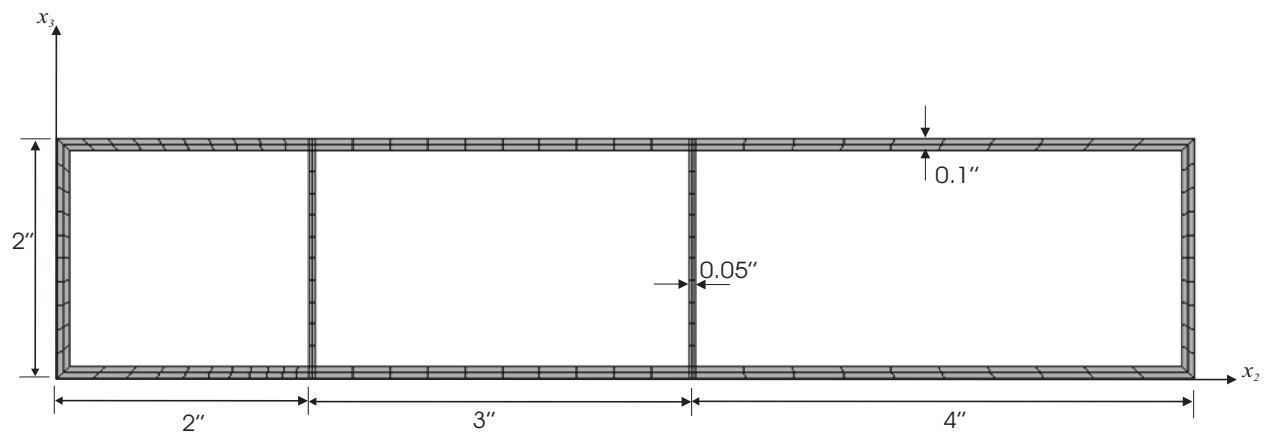

FIGURE 6:

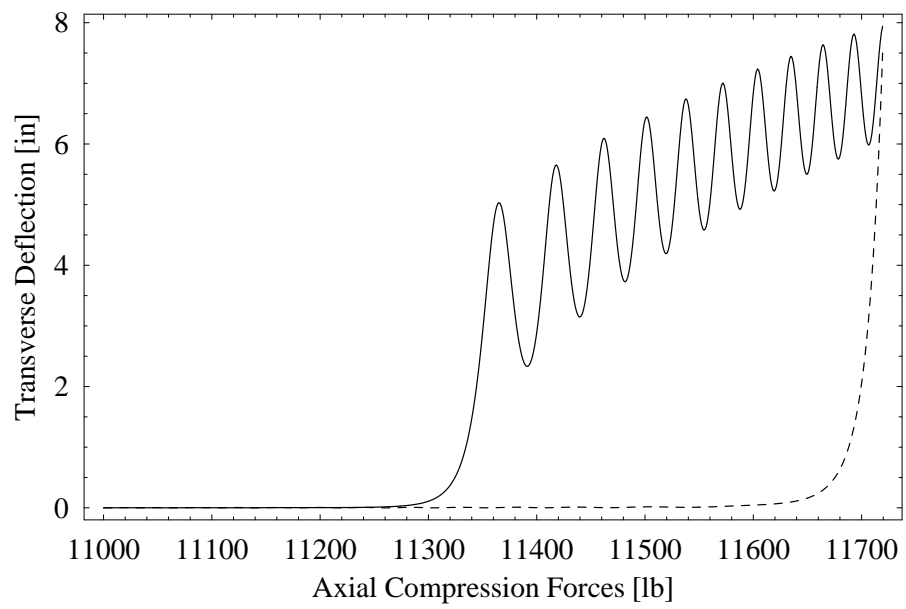

FIGURE 7:

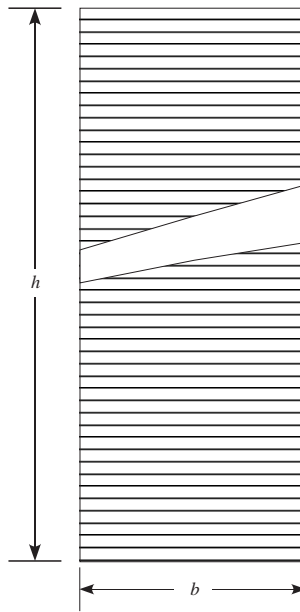

FIGURE 8:

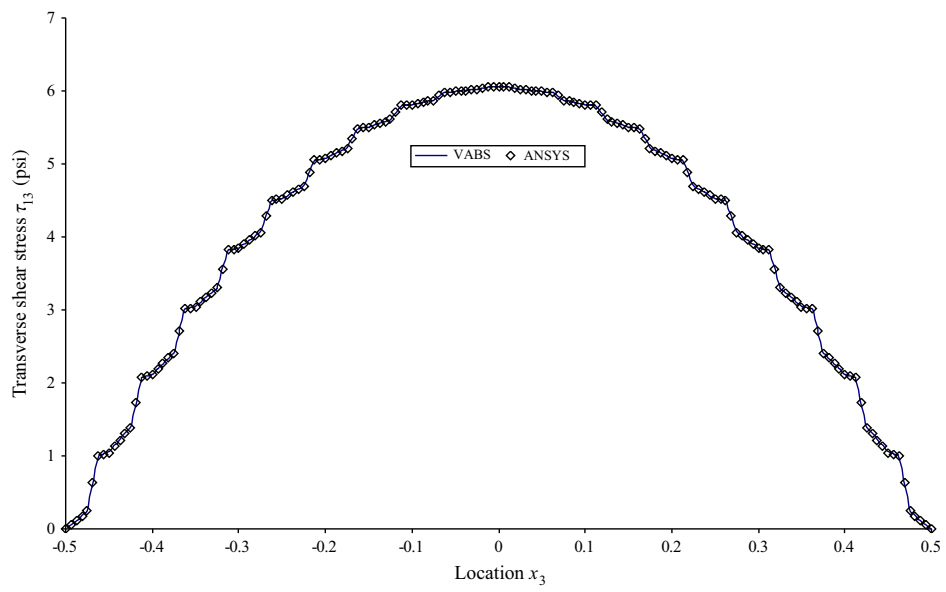

FIGURE 9:

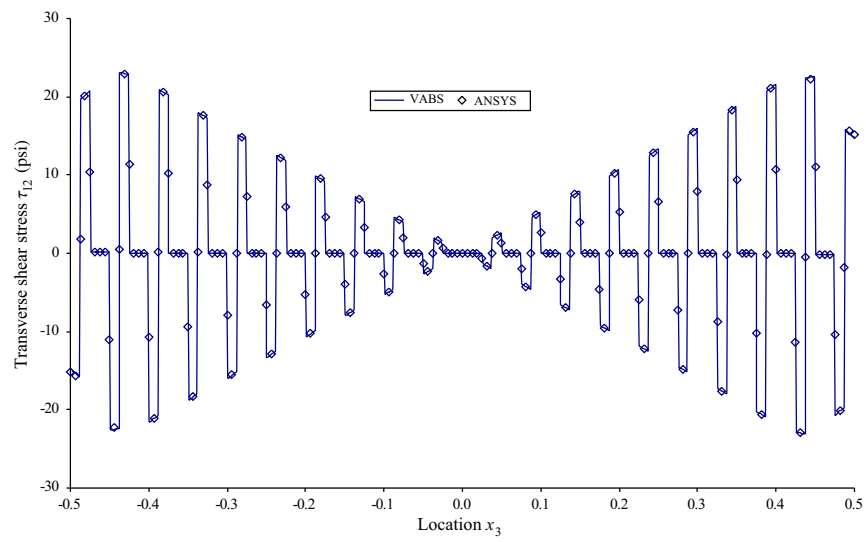

FIGURE 10: